

Client _____ Quantity _____
 Project _____ Position _____

Modi Active Blast Chiller

Model: W5AG

Cod: W11036010001



Abbattitore multifunzione Modi versione Active 5 teglie, profondità 700 mm, Plug-In con condensazione ad aria, classe climatica 5, range di temperatura -40°+65°C. Touch screen 4,3" sulla porta, carter apribile senza attrezzi, è dotato delle funzioni: abbattimento, surgelazione, ciclo manuale, decongelamento, lievitazione, mantenimento, essiccazione, cioccolato. Modalità di funzionamento con ricette personalizzabili, a tempo o con sonda al cuore. Ventilazione regolabile 25-100%. Dotato di 5 posizioni per teglie GN1/1. Sistema Cosmo per la connessione wi-fi e monitoraggio da remoto.

Technical data

Top:	Thickness 4 cm. Reinforced in order to place an oven
Gross capacity:	102 lt
Temperature range:	-40°+65°C
Ventilation range:	25% - 100%
Humidifier:	Not available
Refrigerant unit:	Plug-In
Yield +90 / +3:	20 Kg
Yield +90 / -18:	14 Kg
Climate class:	5
Cooling gas:	R452a
Defrost:	Hot gas
Valve:	Electronic expansion valve
Dimensions (mm):	710×700×853 mm
Packing dimensions:	805×800×901 mm
Gross weight:	105 Kg
Voltage:	220-240 V - 50 Hz
Total rate:	1430 W
Absorbed Current:	6,91 A
Cooling capacity:	1565 W*
*:	Evap. -10°C Cond. +45°C

Features

Functions:	Blast chilling, shock freezing, thawing, proving, holding, desiccation, chocolate, manual cycle
Standard equipment:	Support for 5 positions GN1/1
Control:	4,3" touch screen display with USB port
Doors:	Cushioned, with anti-odor system
Door gasket:	Magnetic, triple chamber and easily replaceable
Core probe:	Needle probe with 1 reading point, quick-release and easily replaceable
Insulation:	60 mm thickness - CFC/HCFC free
Exterior/interior finishing:	Exterior and interior AISI 304 stainless steel.
Inner corners:	Rounded for easy cleaning and ensuring maximum hygiene
Handle:	Stainless steel AISI 304, 2 mm thick
Racks and slides:	Structure in stainless steel wire AISI 304
Feets:	Stainless steel AISI 304, adjustable h 100-150 mm
Cosmo:	Wi-Fi remote control system

Accessories and variants

- _____ RAL customisable colouring
- _____ Sonda al cuore a 3 punti di lettura
- _____ Sonda al cuore riscaldata a 1 punto di lettura
- _____ Inversione apertura porta
- _____ Power supply frequency 60Hz
- _____ Other special voltage
- _____ Lowered foot h 55/70 mm
- _____ 4 Swivel and brake castors h 128 mm
- _____ Stainless steel shelf GN1/1
- _____ Plastic coated shelf GN1/1

COSMO - wi-fi control

Cosmo is the wi-fi technology that allow to connect, update and monitor with a smartphone the MODI blast chiller. MODI is also a Cosmo hub and allow remote supervision of the Coldline devices connected to it.

*The installation requires a kit for the replacement of the racks

Technical draw

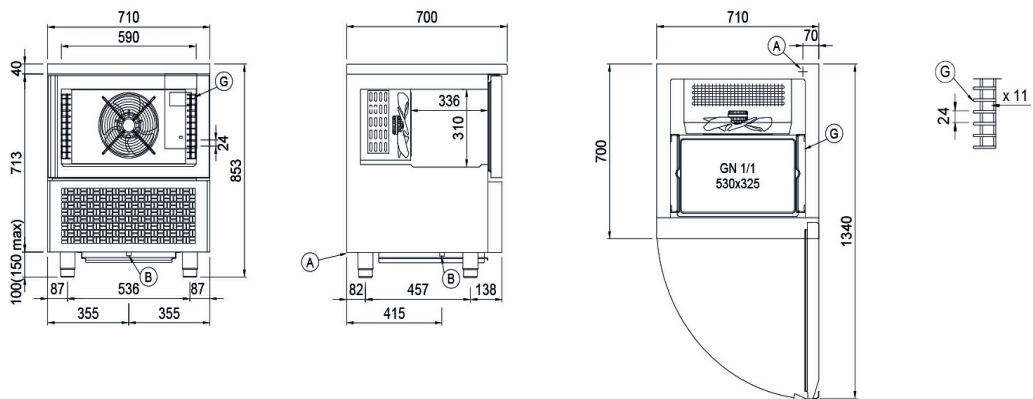

A: Power supply cable outlet

B: Condensation water drain

G: Racks pitch

In order to constantly offer the best possible products we reserve the right to make changes on technical specifications without incurring any obligation for equipment previously or subsequently sold.