

Client _____ Quantity _____
 Project _____ Position _____

Master GN counter 3 doors

Model: TA17/1M-710

Cod: T10302000201



Tavolo refrigerato Master piano con alzatina, Plug-In, 3 porte con altezza corpo tavolo 710 mm, classe energetica A, classe climatica 5 heavy duty e gas refrigerante ecologico R290. Completo di 1 griglia GN1/1, configurabile con cassettiere 1/2+1/2, 1/3+2/3, 1/3+1/3+1/3. Range di temperatura -2°+8°C con refrigerazione ventilata. Struttura con isolamento 60 mm. Interno/esterno in acciaio inox AISI 304 compreso schiena esterna, fondo esterno in acciaio colaminato. Realizzato con tecnologia FSS - Fast Service System - per un service facile e veloce. Predisposto per collegamento a sistema di supervisione remoto.

Technical data

Top:	With top and splashback
Gross capacity:	440 lt
Temperature range:	-2°+8°C
Refrigerant unit:	Plug-In
Energetic class:	A
Energy efficiency index:	24,7
Annual consumption:	616 kW/h annum
24h consumption:	1,688 kW/h/24h
Climate class:	5
Cooling gas:	R290
Defrost:	Hot gas
Body height:	710 mm
Valve:	Supplied standard with solenoid
Dimensions (mm):	1780×700×950 mm
Packing dimensions:	1875×800×998 mm
Gross weight:	165 Kg
Voltage:	220-240 V - 50 Hz
Total rate:	250 W
Absorbed Current:	1,15 A
Cooling capacity:	406 W*
*:	Evap. -10°C Cond. +55°C

Features

Standard equipment:	3 coppie guida, 3 griglie plastificate GN1/1
Control:	Electronic, display flush with the panel
Doors:	3 doors, self-closing, reversible with 105° stop
Door gasket:	Magnetic, triple chamber and easily replaceable
Insulation:	60 mm thickness - CFC/HCFC free
Exterior/interior finishing:	Exterior interior and back in AISI 304 stainless steel. Base in colaminated steel
Inner corners:	Rounded for easy cleaning and ensuring maximum hygiene
Handle:	Stainless steel AISI 304, 2 mm thick
Racks and slides:	Stainless steel AISI 304
Feets:	Stainless steel AISI 304, adjustable h 100-150 mm
Cosmo:	Ready for connection to Cosmo Hub

Accessories and variants

Drawers 1/2	Granite flat worktop
Drawers 1/3	Granite worktop with splashback
Drawers 1/3 + 2/3	Service water sink Ø 300 mm
Special counter body heights 650 mm	Single lever mixer hole Ø 3/4
Special counter body heights 700 mm	Adjustable feet h 145/195 mm
Special counter body heights 750 mm	4 Swivel and brake castors h 128 mm
Technical compartment on the left	Brackets for GN pans for drawer
Lock with key for drawer 1/2	GN1/2 container + lids kit for drawer, h 150 mm
Lock with key for drawer 1/3	GN1/3 container + lids kit for drawer, h 150 mm
Lock with key for drawer 1/3 + 2/3	Bottles shelf, stainless steel coating for shelf 350
Glass door	Stainless steel shelf GN1/1
LED lighting	Plastic coated shelf GN1/1
RAL customisable colouring	Pair of type C slides 505 mm
Plug-in water unit	Serial interface, RS485 cable
Stainless steel evaporator	Cosmo connection kit
Power supply frequency 60Hz	IP44 schuko socket with cover
Other special voltage	Removable plinth GN 3D h 50 mm
Internal hygiene H3	Removable plinth GN 3D h 100 mm

*The installation requires a kit for the replacement of the racks

Technical draw

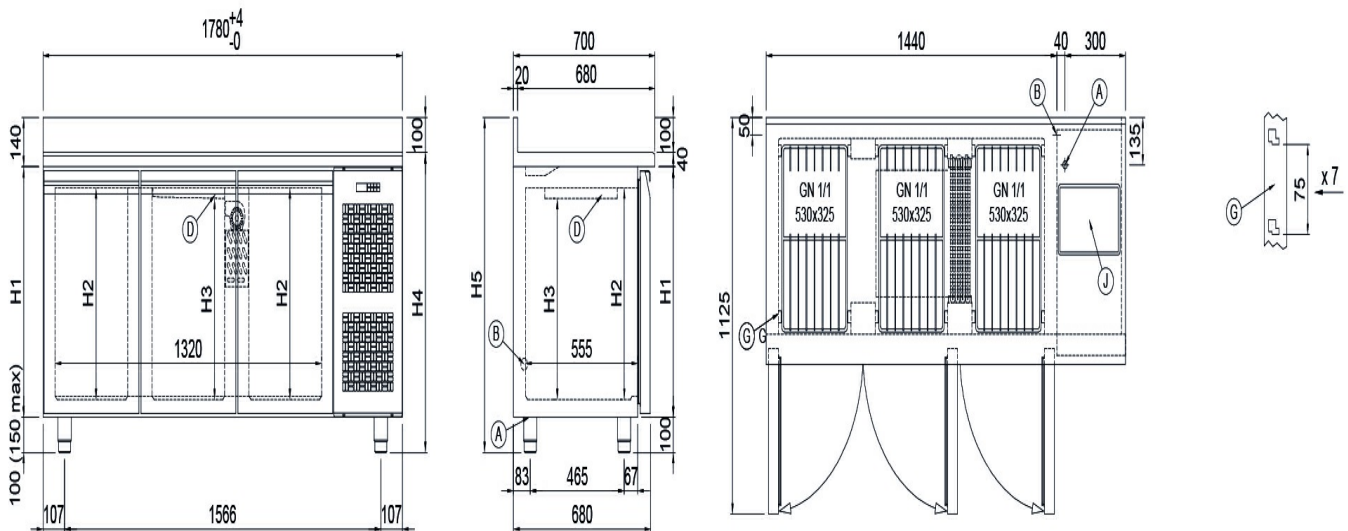

H1	H2	H3	H4	H5
710	600	570	850	950

A: Power supply cable outlet

B: Condensation water drain

D: Airflow conveyor

G: Racks pitch

J: Automatic evaporation of condensing water

In order to constantly offer the best possible products we reserve the right to make changes on technical specifications without incurring any obligation for equipment previously or subsequently sold.