

Client _____ Quantity _____
 Project _____ Position _____

Snack GN counter 2 doors

Model: TP13/1M-490

Cod: T10201000204



Tavolo refrigerato Snack con piano, Plug-In, 2 porte con altezza corpo tavolo 490 mm, classe energetica A, classe climatica 5 heavy duty e gas refrigerante ecologico R290. Completo di 1 griglia GN1/1, configurabile con cassettiere 1/1, 1/2+1/2. Range di temperatura -2°+8°C con refrigerazione ventilata. Struttura con isolamento 60 mm. Interno/esterno in acciaio inox AISI 304 compreso schiena esterna, fondo esterno in acciaio colaminato. Realizzato con tecnologia FSS - Fast Service System - per un service facile e veloce. Predisposto per collegamento a sistema di supervisione remoto.

Technical data

Top:	With top
Gross capacity:	177 lt
Temperature range:	-2°+8°C
Refrigerant unit:	Plug-In
Energetic class:	A
Energy efficiency index:	19,9
Annual consumption:	409 kW/h annum
24h consumption:	1,121 kW/h/24h
Climate class:	5
Cooling gas:	R290
Defrost:	Hot gas
Body height:	490 mm
Valve:	Supplied standard with solenoid
Dimensions (mm):	1300×700×630 mm
Packing dimensions:	1395×800×998 mm
Gross weight:	115 Kg
Voltage:	220-240 V - 50 Hz
Total rate:	250 W
Absorbed Current:	1,15 A
Cooling capacity:	406 W*
*:	Evap. -10°C Cond. +55°C

Features

Standard equipment:	2 slides, 2 plastic coated GN1/1 shelves
Control:	Electronic, display flush with the panel
Doors:	2 doors, self-closing, reversible with 105° stop
Door gasket:	Magnetic, triple chamber and easily replaceable
Insulation:	60 mm thickness - CFC/HCFC free
Exterior/interior finishing:	Exterior interior and back in AISI 304 stainless steel. Base in colaminated steel
Inner corners:	Rounded for easy cleaning and ensuring maximum hygiene
Handle:	Stainless steel AISI 304, 2 mm thick
Racks and slides:	Stainless steel AISI 304
Feets:	Stainless steel AISI 304, adjustable h 100-150 mm
Cosmo:	Ready for connection to Cosmo Hub

Accessories and variants

Drawers 1/1	Pair of type C slides 505 mm
Drawers 1/2	IP44 schuko socket with cover
Special size of technical compartment	Serial interface, RS485 cable
Technical compartment on the left	Cosmo connection kit
Lock with key for drawer 1/1	Removable plinth GN 2D h 50 mm
Lock with key for drawer 1/2	Removable plinth GN 2D h 100 mm
RAL customisable colouring	Removable plinth GN 2D h 150 mm
Plug-in water unit	
Power supply frequency 60Hz	
Other special voltage	
Adjustable feet h 145/195 mm	
4 Swivel and brake castors h 128 mm	
Brackets for GN pans for drawer	
GN1/2 container + lids kit for drawer, h 150 mm	
GN1/3 container + lids kit for drawer, h 150 mm	
Bottles shelf, stainless steel coating for shelf 350	
Stainless steel shelf GN1/1	
Plastic coated shelf GN1/1	

COSMO - wi-fi control

Cosmo is the wi-fi technology that allow to connect and monitor all Coldline appliances. Connect Snack counters to a Cosmo hub (MODI, VISION or LEVTRONIC) and from the app you can check the operating conditions of each machine and receive alerts in case of abnormal functioning.

*The installation requires a kit for the replacement of the racks

Technical draw

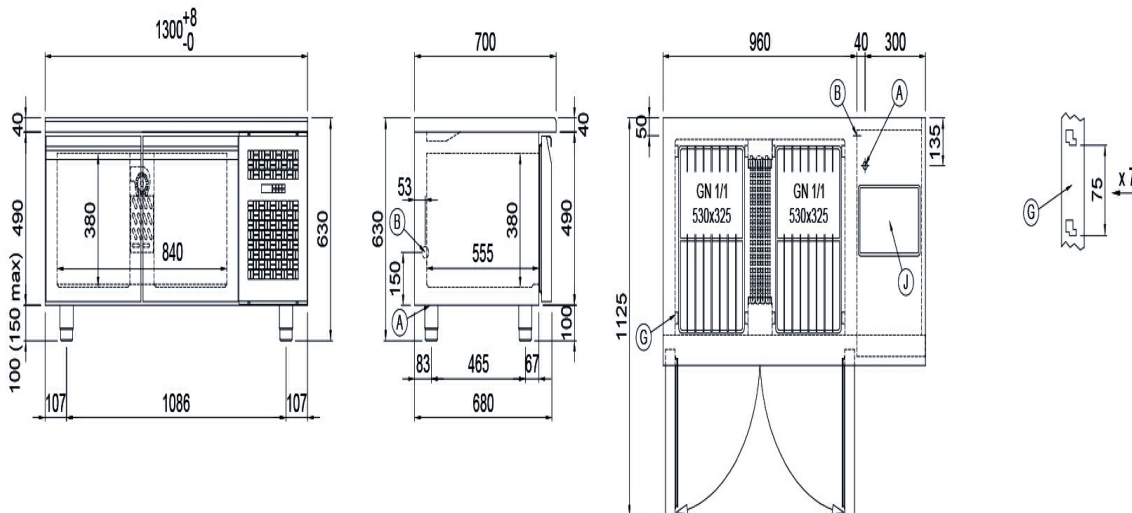

- A:** Power supply cable outlet **B:** Condensation water drain **G:** Racks pitch
J: Automatic evaporation of condensing water

In order to constantly offer the best possible products we reserve the right to make changes on technical specifications without incurring any obligation for equipment previously or subsequently sold.