

Client _____ Quantity _____
 Project _____ Position _____

Smart GN counter 3 doors

Model: TP17/1ME-710 **Cod:** T11301000201



Tavolo refrigerato Smart con piano, Plug-In, 3 porte con altezza corpo tavolo 710 mm, classe energetica A, classe climatica 5 heavy duty e gas refrigerante ecologico R290. Completo di 1 griglia GN1/1, configurabile con cassettiere 1/2+1/2, 1/3+2/3, 1/3+1/3+1/3. Range di temperatura -2°+8°C con refrigerazione ventilata. Struttura con isolamento 60 mm. Interno/esterno in acciaio inox AISI 304; schiena esterna e fondo esterno in acciaio colaminato. Realizzato con tecnologia FSS - Fast Service System - per un service facile e veloce. Predisposto per collegamento a sistema di supervisione remoto.

Technical data

Top:	With top
Gross capacity:	440 lt
Temperature range:	-2°+8°C
Refrigerant unit:	Plug-In
Energetic class:	A
Energy efficiency index:	24,7
Annual consumption:	616 kW/h annum
24h consumption:	1,688 kW/h/24h
Climate class:	5
Cooling gas:	R290
Defrost:	Hot gas
Body height:	710 mm
Valve:	Supplied standard with solenoid
Dimensions (mm):	1780×700×850 mm
Packing dimensions:	1875×800×998 mm
Gross weight:	150 Kg
Voltage:	220-240 V - 50 Hz
Total rate:	250 W
Absorbed Current:	1,15 A
Cooling capacity:	406 W*
*:	Evap. -10°C Cond. +55°C

Features

Standard equipment:	3 coppie guida, 3 griglie plastificate GN1/1
Control:	Electronic, display flush with the panel
Doors:	3 doors, self-closing, reversible with 105° stop
Door gasket:	Magnetic, triple chamber and easily replaceable
Insulation:	60 mm thickness - CFC/HCFC free
Exterior/interior finishing:	Interno/esterno in acciaio inox AISI 304; schiena esterna e fondo in acciaio colaminato
Inner corners:	Rounded for easy cleaning and ensuring maximum hygiene
Handle:	In PVC
Racks and slides:	Stainless steel AISI 304
Feets:	Stainless steel AISI 304, adjustable h 100-150 mm
Cosmo:	Ready for connection to Cosmo Hub

Accessories and variants

Drawers 1/2
Drawers 1/3
Drawers 1/3 + 2/3
Power supply frequency 60Hz
Other special voltage
Service water sink Ø 300 mm
Single lever mixer hole Ø 3/4
Adjustable feet h 145/195 mm
4 Swivel and brake castors h 128 mm
Brackets for GN pans for drawer
GN1/2 container + lids kit for drawer, h 150 mm
GN1/3 container + lids kit for drawer, h 150 mm
Stainless steel shelf GN1/1
Plastic coated shelf GN1/1
Pair of type C slides 505 mm
Serial interface, RS485 cable
Cosmo connection kit

COSMO - wi-fi control

Cosmo is the wi-fi technology that allow to connect and monitor all Coldline appliances. Connect Smart counters to a Cosmo hub (MODI, VISION or LEVTRONIC) and from the app you can check the operating conditions of each machine and receive alerts in case of abnormal functioning.

*The installation requires a kit for the replacement of the racks

Technical draw

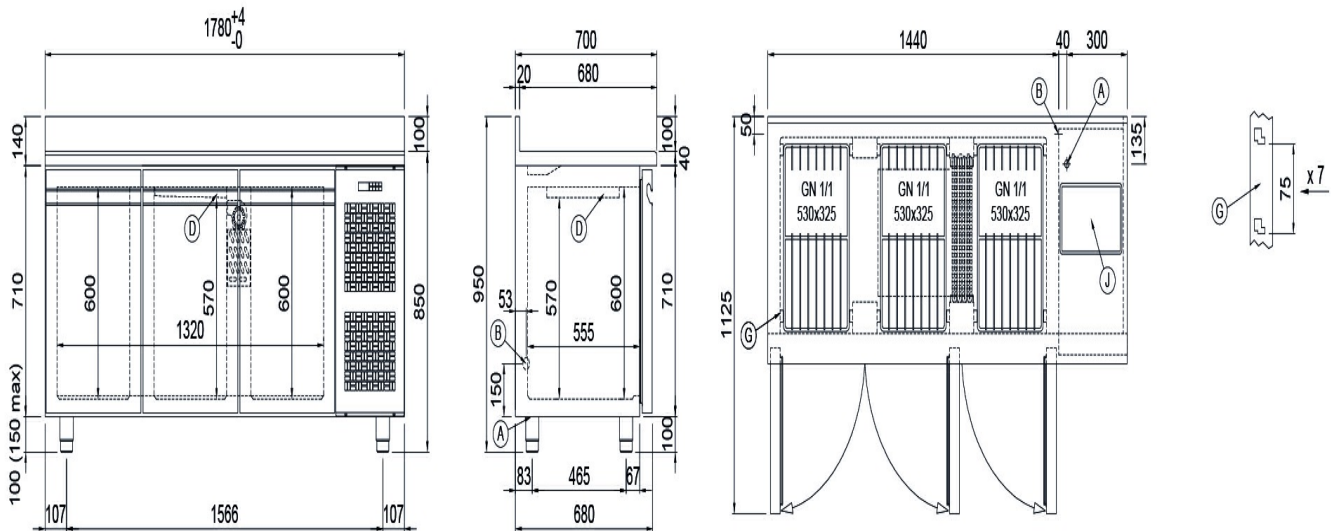

- | | | |
|-------------------------------------|-----------------------------------------------------|----------------------------|
| A: Power supply cable outlet | B: Condensation water drain | D: Airflow conveyor |
| G: Racks pitch | J: Automatic evaporation of condensing water | |

In order to constantly offer the best possible products we reserve the right to make changes on technical specifications without incurring any obligation for equipment previously or subsequently sold.