

Client \_\_\_\_\_ Quantity \_\_\_\_\_  
 Project \_\_\_\_\_ Position \_\_\_\_\_

## Smart GN counter 2 doors

**Model:** TA13/1ME-710

**Cod:** T11202000201



Tavolo refrigerato Smart piano con alzatina, Plug-In, 2 porte con altezza corpo tavolo 710 mm, classe energetica A, classe climatica 5 heavy duty e gas refrigerante ecologico R290. Completo di 1 griglia GN1/1, configurabile con cassettiere 1/2+1/2, 1/3+2/3, 1/3+1/3+1/3. Range di temperatura -2°+8°C con refrigerazione ventilata. Struttura con isolamento 60 mm. Interno/esterno in acciaio inox AISI 304; schiena esterna e fondo esterno in acciaio laminato. Realizzato con tecnologia FSS - Fast Service System - per un service facile e veloce. Predisposto per collegamento a sistema di supervisione remoto.

### Technical data

<b>Top:</b>	With top and splashback
<b>Gross capacity:</b>	280 lt
<b>Temperature range:</b>	-2°+8°C
<b>Refrigerant unit:</b>	Plug-In
<b>Energetic class:</b>	A
<b>Energy efficiency index:</b>	23,3
<b>Annual consumption:</b>	527 kW/h annum
<b>24h consumption:</b>	1,444 kW/h/24h
<b>Climate class:</b>	5
<b>Cooling gas:</b>	R290
<b>Defrost:</b>	Hot gas
<b>Body height:</b>	710 mm
<b>Valve:</b>	Supplied standard with solenoid
<b>Dimensions (mm):</b>	1300×700×950 mm
<b>Packing dimensions:</b>	1395×800×998 mm
<b>Gross weight:</b>	130 Kg
<b>Voltage:</b>	220-240 V - 50 Hz
<b>Total rate:</b>	250 W
<b>Absorbed Current:</b>	1,15 A
<b>Cooling capacity:</b>	406 W*
<b>*:</b>	Evap. -10°C Cond. +55°C

### Features

<b>Standard equipment:</b>	2 slides, 2 plastic coated GN1/1 shelves
<b>Control:</b>	Electronic, display flush with the panel
<b>Doors:</b>	2 doors, self-closing, reversible with 105° stop
<b>Door gasket:</b>	Magnetic, triple chamber and easily replaceable
<b>Insulation:</b>	60 mm thickness - CFC/HCFC free
<b>Exterior/interior finishing:</b>	Interno/esterno in acciaio inox AISI 304; schiena esterna e fondo in acciaio laminato
<b>Inner corners:</b>	Rounded for easy cleaning and ensuring maximum hygiene
<b>Handle:</b>	In PVC
<b>Racks and slides:</b>	Stainless steel AISI 304
<b>Feets:</b>	Stainless steel AISI 304, adjustable h 100-150 mm
<b>Cosmo:</b>	Ready for connection to Cosmo Hub

## Accessories and variants

Drawers 1/2
Drawers 1/3
Drawers 1/3 + 2/3
Power supply frequency 60Hz
Other special voltage
Service water sink Ø 300 mm
Single lever mixer hole Ø 3/4
Adjustable feet h 145/195 mm
4 Swivel and brake castors h 128 mm
Brackets for GN pans for drawer
GN1/2 container + lids kit for drawer, h 150 mm
GN1/3 container + lids kit for drawer, h 150 mm
Stainless steel shelf GN1/1
Plastic coated shelf GN1/1
Pair of type C slides 505 mm
Serial interface, RS485 cable
Cosmo connection kit

## COSMO - wi-fi control

Cosmo is the wi-fi technology that allow to connect and monitor all Coldline appliances. Connect Smart counters to a Cosmo hub (MODI, VISION or LEVTRONIC) and from the app you can check the operating conditions of each machine and receive alerts in case of abnormal functioning.

\*The installation requires a kit for the replacement of the racks

## Technical draw

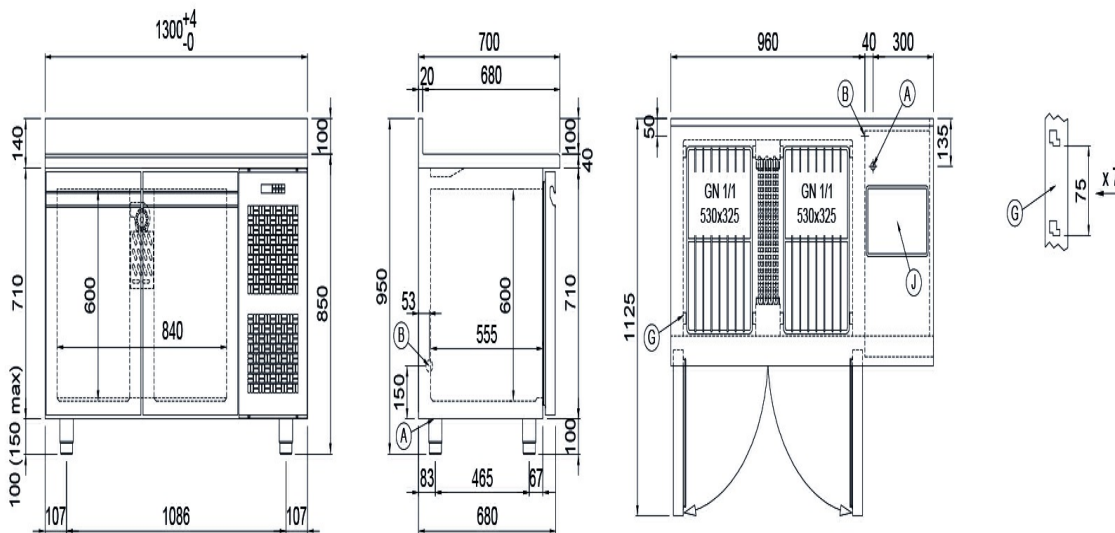

A: Power supply cable outlet

B: Condensation water drain

G: Racks pitch

J: Automatic evaporation of condensing water

In order to constantly offer the best possible products we reserve the right to make changes on technical specifications without incurring any obligation for equipment previously or subsequently sold.