



Client \_\_\_\_\_ Quantity \_\_\_\_\_  
 Project \_\_\_\_\_ Position \_\_\_\_\_

## Armadio Master 500 It

**Model:** A50/1MV

**Cod:** A14050200601

Armadio refrigerato Master 500 litri Plug-In, 1 porta vetro con maniglia inox, classe climatica 4 e gas refrigerante ecologico R290. Serratura con chiave, illuminazione strip LED, completo di 3 griglie plastificate 42x53 cm. Range di temperatura -2°+8°C; refrigerazione ventilata. Evaporatore trattato anticorrosione. Struttura monoscocca con isolamento 75 mm. Interno/esterno in acciaio inox AISI 304; schiena esterna, fondo esterno e interno vano tecnico in acciaio galvanizzato/colaminato. Sistema refrigerante sostituibile FSS - Fast Service System - per un service facile e veloce. Predisposto per collegamento a sistema di supervisione remoto.

### Technical data

<b>Gross capacity:</b>	417 lt
<b>Temperature range:</b>	-2°+8°C
<b>Refrigerant unit:</b>	Plug-In
<b>Energetic class:</b>	C
<b>Energy efficiency index:</b>	46,9
<b>Annual consumption:</b>	509 kW/h annum
<b>24h consumption:</b>	1,394 kW/h/24h
<b>Climate class:</b>	4
<b>Cooling gas:</b>	R290
<b>Defrost:</b>	Hot gas
<b>Valve:</b>	Supplied standard with solenoid
<b>Dimensions (mm):</b>	630×715×2085 mm
<b>Packing dimensions:</b>	835×830×2144 mm
<b>Gross weight:</b>	140 Kg
<b>Voltage:</b>	220-240 V - 50 Hz
<b>Total rate:</b>	260 W
<b>Absorbed Current:</b>	1,2 A
<b>Cooling capacity:</b>	406 W*
<b>*:</b>	Evap. -10°C Cond. +55°C

### Features

<b>Standard equipment:</b>	3 slides for 42x53 cm shelves 3 plastic coated 42x53 cm shelves, lock with key, LED lighting
<b>Control:</b>	Electronic, display flush with the panel
<b>Doors:</b>	1 aluminum door, self-closing with a 105° stop, right hinged
<b>Door gasket:</b>	Magnetic, triple chamber and easily replaceable
<b>Insulation:</b>	75 mm thickness - CFC/HCFC free
<b>Exterior/interior finishing:</b>	Exterior and interior AISI 304 stainless steel. Back, base and internal technical compartment in galvanized/ colaminated steel.
<b>Inner corners:</b>	Rounded for easy cleaning and ensuring maximum hygiene
<b>Handle:</b>	Stainless steel AISI 304, 2 mm thick
<b>Racks and slides:</b>	Stainless steel AISI 304
<b>Feets:</b>	Stainless steel AISI 304, adjustable h 100-150 mm
<b>Cosmo:</b>	Ready for connection to Cosmo Hub

## Accessories and variants

- Special rack kit for drawers and shelves
- Power supply frequency 60Hz
- Other special voltage
- Half doors
- Frame for fixed masonry plinth
- RAL customisable colouring
- Master Marine solutions
- Predisposition for connection to CO2 remote control unit
- Plug-in water unit
- Kit für Öffnung der Tür mit Pedal
- 4 Swivel and brake castors h 128 mm
- Plastic coated shelf 42x53
- Pair of type C slides 505 mm
- Stainless steel drawer, h 150 mm 500
- Bottles shelf, stainless steel coating for shelf 500
- Serial interface, RS485 cable
- Cosmo connection kit

### COSMO - wi-fi control

Cosmo is the wi-fi technology that allow to connect and monitor all Coldline appliances. Connect Master cabinets to a Cosmo hub (MODI, VISION or LEVTRONIC) and from the app you can check the operating conditions of each machine and receive alerts in case of abnormal functioning.

\*The installation requires a kit for the replacement of the racks

## Technical draw

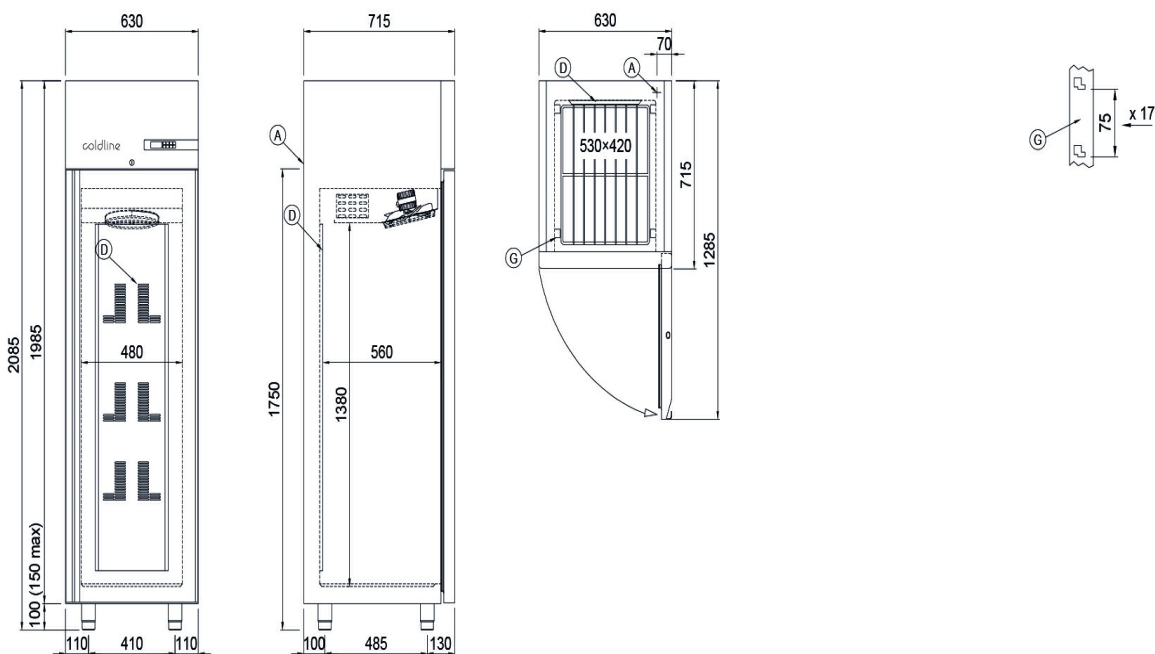

A: Power supply cable outlet

D: Airflow conveyer

G: Racks pitch

In order to constantly offer the best possible products we reserve the right to make changes on technical specifications without incurring any obligation for equipment previously or subsequently sold.