



Client _____ Quantity _____
 Project _____ Position _____

Master Combi 700 cabinet

Model: A70/2MM

Cod: A14070220201

Armadio refrigerato Master Combi 700 litri Plug-In, 2 porte con maniglia inox, 2 vani separati con 2 temperature di funzionamento, classe energetica C, classe climatica 5 heavy duty e gas refrigerante ecologico R290. Serratura con chiave, illuminazione, completo di 2+2 griglie plastificate GN2/1. Range di temperatura vano A: -2°+8°C; Vano B: -2°+8°C; refrigerazione ventilata. Evaporatori trattati anticorrosione. Struttura monoscocca con isolamento 75 mm. Interno/esterno in acciaio inox AISI 304; schiena esterna, fondo esterno e interno vano tecnico in acciaio galvanizzato/colaminato. Predisposto per collegamento a sistema di supervisione remoto.

Technical data

Gross capacity:	562 lt
Temperature range:	-2°+8°C/-2°+8°C
Refrigerant unit:	Plug-In
Energetic class:	C
Energy efficiency index:	40,7
Annual consumption:	478 kW/h annum
24h consumption:	1,31 kW/h/24h
Climate class:	5
Cooling gas:	R290
Defrost:	Hot gas
Valve:	Supplied standard with solenoid
Dimensions (mm):	740×815×2085 mm
Packing dimensions:	835×930×2138 mm
Gross weight:	180 Kg
Voltage:	220-240 V - 50 Hz
Total rate:	520 W
Absorbed Current:	2,4 A
Cooling capacity:	406 W*
Cooling capacity 2:	406 W*
*:	Evap. -10°C Cond. +55°C

Features

Standard equipment:	3 slides for GN1/1 shelves, 3 abs GN1/1 pans, lock with key, LED lighting
Control:	Electronic, display flush with the panel
Doors:	1 door, self-closing with a 105° stop, right hinged
Door gasket:	Magnetic, triple chamber and easily replaceable
Insulation:	75 mm thickness - CFC/HCFC free
Exterior/interior finishing:	Exterior and interior AISI 304 stainless steel. Back, base and internal technical compartment in galvanized/ colaminated steel.
Inner corners:	Rounded for easy cleaning and ensuring maximum hygiene
Handle:	Stainless steel AISI 304, 2 mm thick
Racks and slides:	Stainless steel AISI 304
Feets:	Stainless steel AISI 304, adjustable h 100-150 mm
Cosmo:	Ready for connection to Cosmo Hub

Accessories and variants

- Power supply frequency 60Hz
- Other special voltage
- Frame for fixed masonry plinth
- RAL customisable colouring
- Master Marine solutions
- Predisposition for connection to CO2 remote control unit
- Plug-in water unit
- 4 Swivel and brake castors h 128 mm
- Stainless steel shelf GN2/1
- Plastic coated shelf GN2/1
- Pair of type C slides 605 mm
- Stainless steel drawer, h 150 mm 700/1400
- Bottles shelf, stainless steel coating for shelf 700/1400
- Serial interface, RS485 cable
- Cosmo connection kit

COSMO - wi-fi control

Cosmo is the wi-fi technology that allow to connect and monitor all Coldline appliances. Connect Master cabinets to a Cosmo hub (MODI, VISION or LEVTRONIC) and from the app you can check the operating conditions of each machine and receive alerts in case of abnormal functioning.

*The installation requires a kit for the replacement of the racks

Technical draw

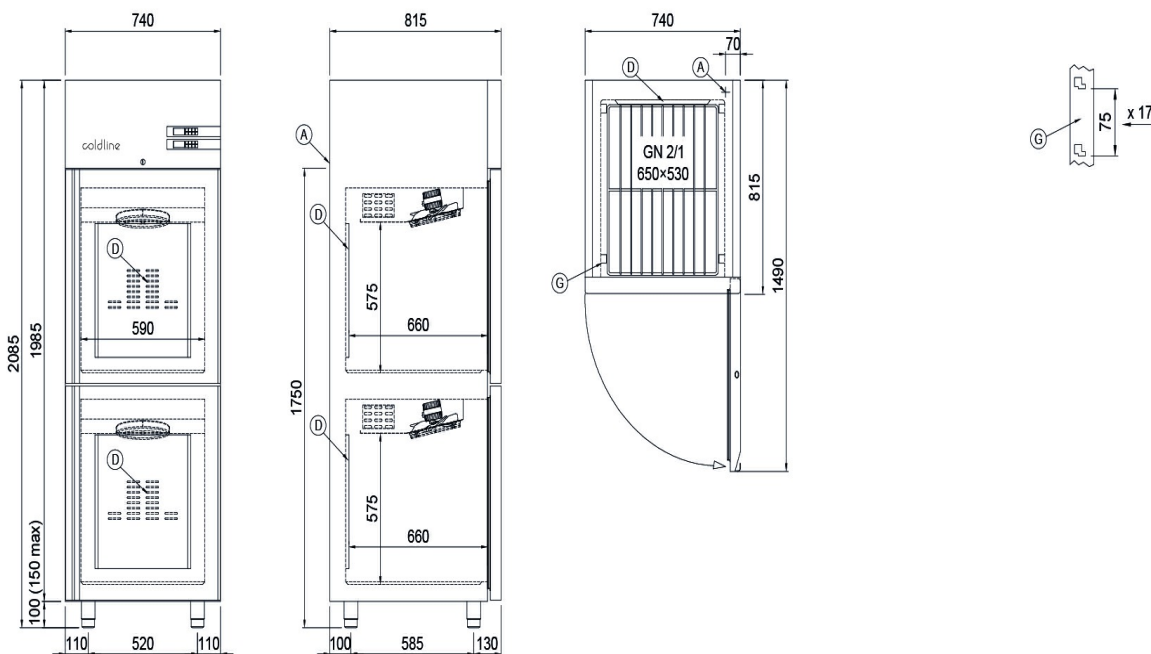

A: Power supply cable outlet

D: Airflow conveyor

G: Racks pitch

In order to constantly offer the best possible products we reserve the right to make changes on technical specifications without incurring any obligation for equipment previously or subsequently sold.