



Client _____ Quantity _____
 Project _____ Position _____

Levtronic 650 cabinet

Model: A80/1FHV

Cod: A32080800601

Armadio Fernalievitazione Levtronic 650 litri Plug-In, 1 porta vetro, classe climatica 4 e gas refrigerante R452. Range di temperatura -6°+40°C e umidità regolabile 45÷95%. Vano con supporti EN60x40, illuminazione strip LED, serratura con chiave, piletta di scolo, completo di 20 coppie guida. Filtro di purificazione acqua incluso. Struttura monoscocca con isolamento 75 mm. Interno/esterno in acciaio inox AISI 304; schiena esterna, fondo esterno e interno vano tecnico in acciaio galvanizzato/colaminato. Realizzato con tecnologia FSS - Fast Service System - per un service facile e veloce. Sistema Cosmo per la connessione wi-fi e monitoraggio da remoto.

Technical data

Max capacity:	34 trays EN60x40
Gross capacity:	573 lt
Temperature range:	-6°+40°C
Ventilation range:	25% - 100%
Humidity range:	45% - 95% with humidifier
Humidifier:	Included
Refrigerant unit:	Plug-In
Energetic class:	E
Energy efficiency index:	81,9
Annual consumption:	920 kW/h annum
24h consumption:	2,520 kW/h/24h
Climate class:	4
Cooling gas:	R290
Defrost:	Electric
Valve:	Supplied standard with solenoid
Dimensions (mm):	810×715×2085
Packing dimensions:	905×830×2138 mm
Gross weight:	170 Kg
Voltage:	220-240 V - 50 Hz
Total rate:	1360 W
Absorbed Current:	6,2 A
Cooling capacity:	668 W*
*:	Evap. -10°C Cond. +55°C

Features

Functions:	Manual proving, retarder prover, continuous cycle, storage
Standard equipment:	20 slides for EN60x40 trays, lock with key, water drain, LED lighting
Control:	4,3" touch screen display with USB port
Doors:	1 aluminum door, self-closing with a 105° stop, right hinged
Door gasket:	Magnetic, triple chamber and easily replaceable
Insulation:	75 mm thickness - CFC/HCFC free
Exterior/interior finishing:	Exterior and interior AISI 304 stainless steel. Back, base and internal technical compartment in galvanized/ colaminated steel.
Inner corners:	Rounded for easy cleaning and ensuring maximum hygiene
Handle:	Stainless steel AISI 304, 2 mm thick
Racks and slides:	Stainless steel AISI 304
Feets:	Stainless steel AISI 304, adjustable h 100-150 mm
Cosmo:	Wi-Fi remote control system

Accessories and variants

- _____ RAL customisable colouring
- _____ Stainless steel evaporator
- _____ Power supply frequency 60Hz
- _____ Other special voltage
- _____ Kit für Öffnung der Tür mit Pedal
- _____ Purity C Quell ST 50 filter cartridge
- _____ Aluminium coated backing-pan EN60x40 h 20 mm
- _____ Stainless steel shelf EN60x40
- _____ Plastic coated shelf EN60x40
- _____ Pair of type L slides 398 mm EN
- _____ Serial interface, RS485 cable

COSMO - wi-fi control

Cosmo is the wi-fi technology that allow to connect, update and monitor with a smartphone the LEVTRONIC retarder prover devices. VISION is also a Cosmo hub and allow remote supervision of the Coldline devices connected to it. From the app you can check the operating conditions of each machine and receive alerts in the event of abnormal operation.

*The installation requires a kit for the replacement of the racks

Technical draw

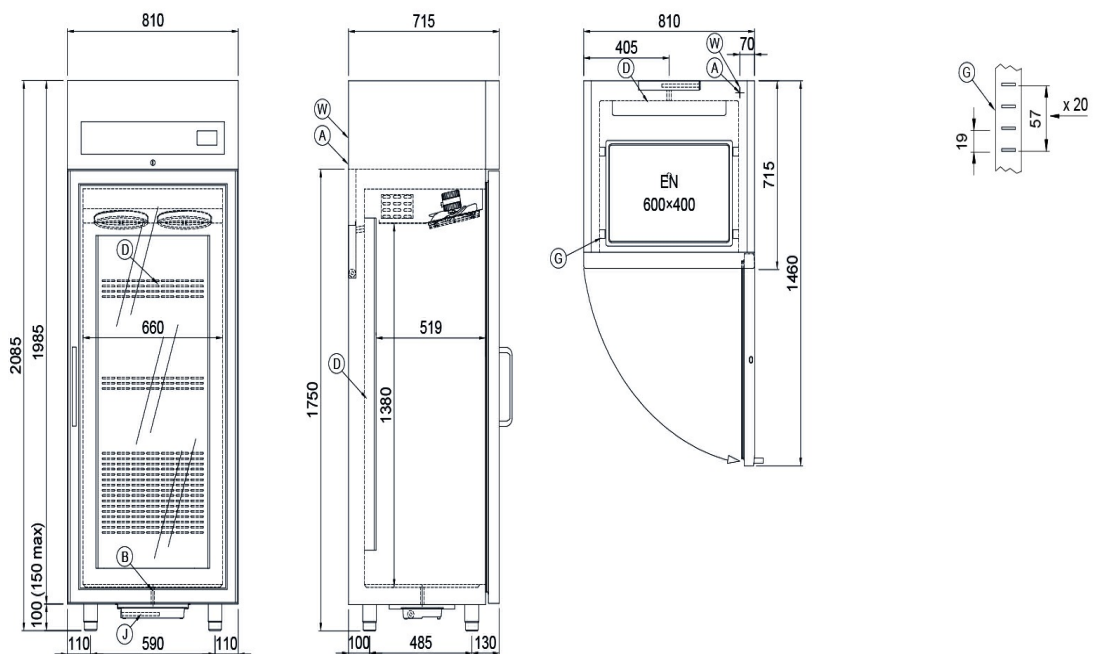

- | | | |
|-------------------------------------|---|---|
| A: Power supply cable outlet | B: Condensation water drain | D: Airflow conveyor |
| G: Racks pitch | J: Automatic evaporation of condensing water | W: Water mains connection for humidifier - 3/4" female. Unloading not required |

In order to constantly offer the best possible products we reserve the right to make changes on technical specifications without incurring any obligation for equipment previously or subsequently sold.