



Client \_\_\_\_\_ Quantity \_\_\_\_\_  
 Project \_\_\_\_\_ Position \_\_\_\_\_

## Smart 700 cabinet

**Model:** A70/1BE

**Cod:** A12070600101

Armadio refrigerato Smart 700 litri Plug-In, 1 porta con maniglia in PVC, classe energetica C, classe climatica 5 heavy duty e gas refrigerante ecologico R290. Serratura con chiave, completo di 3 griglie plastificate GN2/1. Range di temperatura -18°-22°C; refrigerazione ventilata. Evaporatore trattato anticorrosione. Struttura monoscocca con isolamento 75 mm. Interno/esterno in acciaio inox AISI 304; schiena esterna, fondo esterno e interno vano tecnico in acciaio galvanizzato/colaminato. Sistema refrigerante sostituibile FSS - Fast Service System - per un service facile e veloce. Predisposto per collegamento a sistema di supervisione remoto.

## Technical data

<b>Gross capacity:</b>	601 lt
<b>Temperature range:</b>	-18°-22°C
<b>Refrigerant unit:</b>	Plug-In
<b>Energetic class:</b>	C
<b>Energy efficiency index:</b>	43,6
<b>Annual consumption:</b>	1609 kW/h annum
<b>24h consumption:</b>	4,408 kW/h/24h
<b>Climate class:</b>	5
<b>Cooling gas:</b>	R290
<b>Defrost:</b>	Hot gas
<b>Valve:</b>	Supplied standard with solenoid
<b>Dimensions (mm):</b>	740×815×2085 mm
<b>Packing dimensions:</b>	835×930×2138 mm
<b>Gross weight:</b>	150 Kg
<b>Voltage:</b>	220-240 V - 50 Hz
<b>Total rate:</b>	810 W
<b>Absorbed Current:</b>	3,7 A
<b>Cooling capacity:</b>	453 W*
<b>*:</b>	Evap. -30°C Cond. +55°C

## Features

<b>Standard equipment:</b>	3 slides for GN2/1 shelves, 3 plastic coated GN2/1 shelves, lock with key
<b>Control:</b>	Electronic, display flush with the panel
<b>Doors:</b>	1 door, self-closing with a 105° stop, right hinged
<b>Door gasket:</b>	Magnetic, triple chamber and easily replaceable
<b>Insulation:</b>	75 mm thickness - CFC/HCFC free
<b>Exterior/interior finishing:</b>	Exterior and interior AISI 304 stainless steel. Back, base and internal technical compartment in galvanized/ colaminated steel.
<b>Inner corners:</b>	Rounded for easy cleaning and ensuring maximum hygiene
<b>Handle:</b>	In PVC
<b>Racks and slides:</b>	Stainless steel AISI 304
<b>Feets:</b>	Stainless steel AISI 304, adjustable h 100-150 mm
<b>Cosmo:</b>	Ready for connection to Cosmo Hub

## Accessories and variants

Power supply frequency 60Hz  
 Other special voltage  
 Half doors Smart  
 Frame for fixed masonry plinth  
 Kit für Öffnung der Tür mit Pedal  
 4 Swivel and brake castors h 128 mm  
 1 door LED lighting  
 Stainless steel shelf GN2/1  
 Plastic coated shelf GN2/1  
 Pair of type C slides 605 mm  
 Serial interface, RS485 cable  
 Cosmo connection kit

### COSMO - wi-fi control

Cosmo is the wi-fi technology that allow to connect and monitor all Coldline appliances. Connect Smart cabinets to a Cosmo hub (MODI, VISION or LEVTRONIC) and from the app you can check the operating conditions of each machine and receive alerts in case of abnormal functioning.

\*The installation requires a kit for the replacement of the racks

## Technical draw

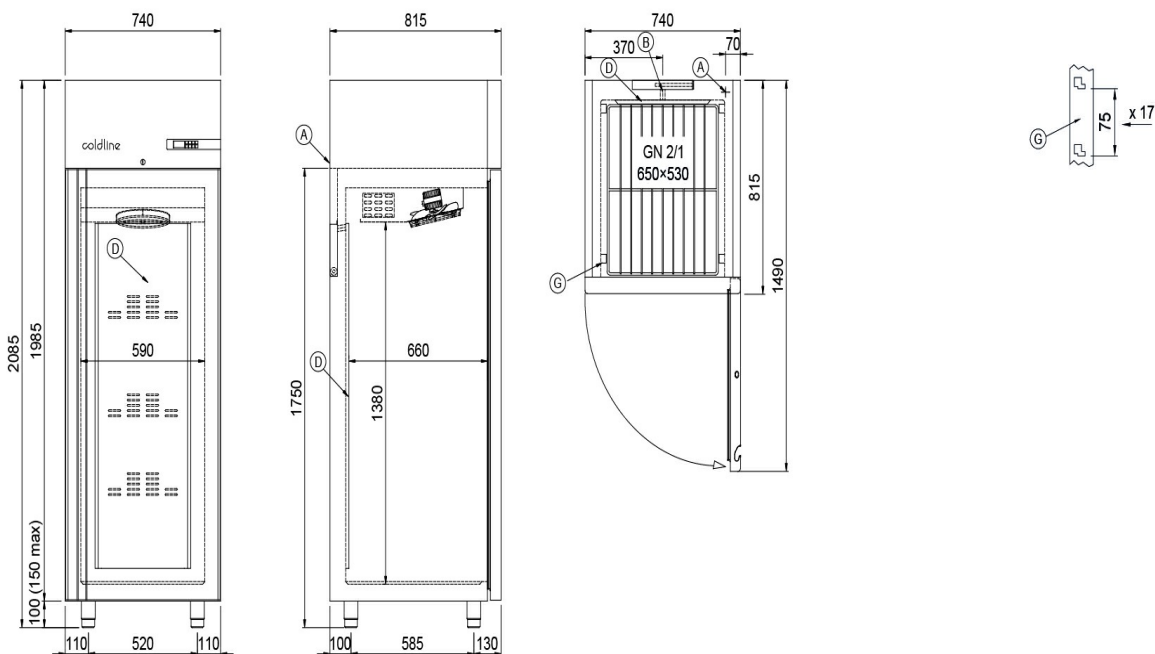

A: Power supply cable outlet

D: Airflow conveyor

G: Racks pitch

In order to constantly offer the best possible products we reserve the right to make changes on technical specifications without incurring any obligation for equipment previously or subsequently sold.