



Client _____ Quantity _____
Project _____ Position _____

Smart 600 cabinet

Model: A60/1BE

Cod: A12060600101

Armadio refrigerato Smart 600 litri Plug-In, 1 porta con maniglia in PVC, classe energetica C, classe climatica 5 heavy duty e gas refrigerante ecologico R290. Serratura con chiave, completo di 3 griglie plastificate 53x53 cm. Range di temperatura -18°-22°C; refrigerazione ventilata. Evaporatore trattato anticorrosione. Struttura monoscocca con isolamento 75 mm. Interno/esterno in acciaio inox AISI 304; schiena esterna, fondo esterno e interno vano tecnico in acciaio galvanizzato/colaminato. Sistema refrigerante sostituibile FSS - Fast Service System - per un service facile e veloce. Predisposto per collegamento a sistema di supervisione remoto.

Technical data

Gross capacity:	512 lt
Temperature range:	-18°-22°C
Refrigerant unit:	Plug-In
Energetic class:	C
Energy efficiency index:	44
Annual consumption:	1444 kW/h annum
24h consumption:	3,956 kW/h/24h
Climate class:	5
Cooling gas:	R290
Defrost:	Hot gas
Valve:	Supplied standard with solenoid
Dimensions (mm):	740×715×2085 mm
Packing dimensions:	835×830×2144 mm
Gross weight:	140 Kg
Voltage:	220-240 V - 50 Hz
Total rate:	810 W
Absorbed Current:	3,7 A
Cooling capacity:	453 W*
*:	Evap. -30°C Cond. +55°C

Features

Standard equipment:	3 slides for 53x53 cm shelves, 3 plastic coated 53x53 cm shelves, lock with key
Control:	Electronic, display flush with the panel
Doors:	1 door, self-closing with a 105° stop, right hinged
Door gasket:	Magnetic, triple chamber and easily replaceable
Insulation:	75 mm thickness - CFC/HCFC free
Exterior/interior finishing:	Exterior and interior AISI 304 stainless steel. Back, base and internal technical compartment in galvanized/ colaminated steel.
Inner corners:	Rounded for easy cleaning and ensuring maximum hygiene
Handle:	In PVC
Racks and slides:	Stainless steel AISI 304
Feets:	Stainless steel AISI 304, adjustable h 100-150 mm
Cosmo:	Ready for connection to Cosmo Hub

Accessories and variants

Power supply frequency 60Hz
 Other special voltage
 Half doors Smart
 Frame for fixed masonry plinth
 Kit für Öffnung der Tür mit Pedal
 4 Swivel and brake castors h 128 mm
 1 door LED lighting
 Plastic coated shelf 53x53
 Pair of type C slides 505 mm
 Serial interface, RS485 cable
 Cosmo connection kit

COSMO - wi-fi control

Cosmo is the wi-fi technology that allow to connect and monitor all Coldline appliances. Connect Smart cabinets to a Cosmo hub (MODI, VISION or LEVTRONIC) and from the app you can check the operating conditions of each machine and receive alerts in case of abnormal functioning.

*The installation requires a kit for the replacement of the racks

Technical draw

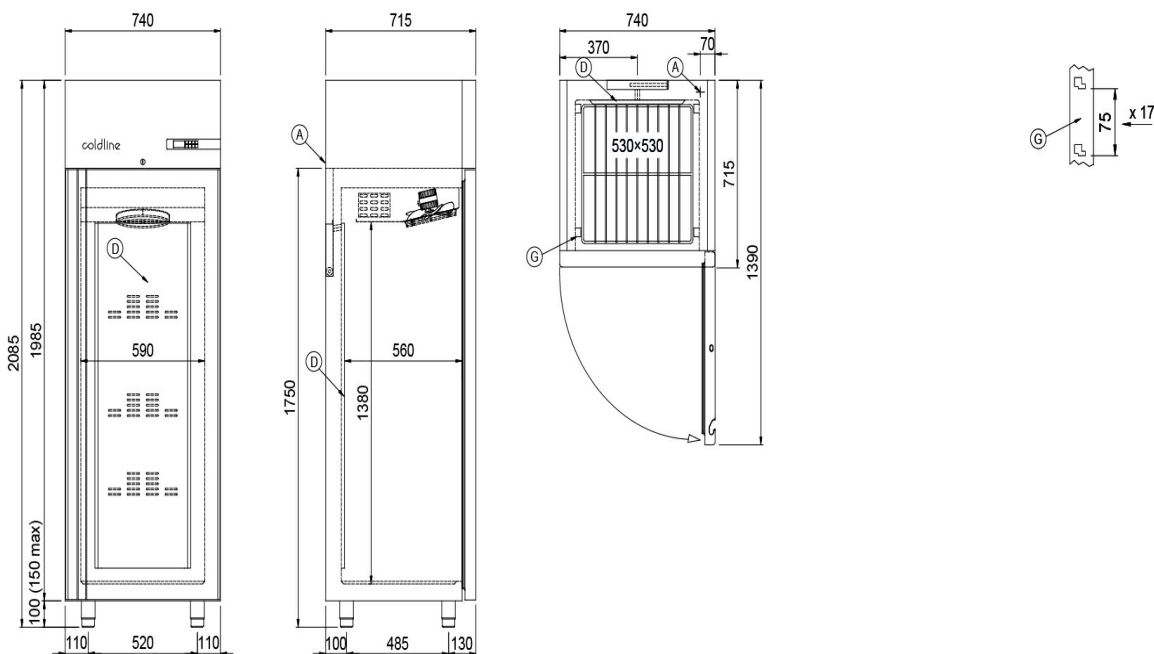

A: Power supply cable outlet

D: Airflow conveyor

G: Racks pitch

In order to constantly offer the best possible products we reserve the right to make changes on technical specifications without incurring any obligation for equipment previously or subsequently sold.