



Client \_\_\_\_\_ Quantity \_\_\_\_\_  
 Project \_\_\_\_\_ Position \_\_\_\_\_

## Master 350 cabinet

**Model:** A30/1B

**Cod:** A14030600101

Armadio refrigerato Master 350 litri Plug-In, 1 porta con maniglia inox, classe energetica C, classe climatica 5 heavy duty e gas refrigerante ecologico R290. Serratura con chiave, illuminazione, completo di 3 griglie plastificate GN1/1. Range di temperatura -18°-22°C; refrigerazione ventilata. Evaporatore trattato anticorrosione. Struttura monoscocca con isolamento 75 mm. Interno/esterno in acciaio inox AISI 304; schiena esterna, fondo esterno e interno vano tecnico in acciaio galvanizzato/colaminato. Sistema refrigerante sostituibile FSS - Fast Service System - per un service facile e veloce. Predisposto per collegamento a sistema di supervisione remoto.

## Technical data

<b>Gross capacity:</b>	334 lt
<b>Temperature range:</b>	-18°-22°C
<b>Refrigerant unit:</b>	Plug-In
<b>Energetic class:</b>	C
<b>Energy efficiency index:</b>	39
<b>Annual consumption:</b>	1006 kW/h annum
<b>24h consumption:</b>	2,756 kW/h/24h
<b>Climate class:</b>	5
<b>Cooling gas:</b>	R290
<b>Defrost:</b>	Hot gas
<b>Valve:</b>	Supplied standard with solenoid
<b>Dimensions (mm):</b>	535×715×2085 mm
<b>Packing dimensions:</b>	835×830×2144 mm
<b>Gross weight:</b>	125 Kg
<b>Voltage:</b>	220-240 V - 50 Hz
<b>Total rate:</b>	810 W
<b>Absorbed Current:</b>	3,7 A
<b>Cooling capacity:</b>	453 W*
<b>*:</b>	Evap. -30°C Cond. +55°C

## Features

<b>Standard equipment:</b>	3 slides for GN1/1 shelves, 3 plastic coated GN1/1 shelves, lock with key, LED lighting
<b>Control:</b>	Electronic, display flush with the panel
<b>Doors:</b>	1 door, self-closing with a 105° stop, right hinged
<b>Door gasket:</b>	Magnetic, triple chamber and easily replaceable
<b>Insulation:</b>	75 mm thickness - CFC/HCFC free
<b>Exterior/interior finishing:</b>	Exterior and interior AISI 304 stainless steel. Back, base and internal technical compartment in galvanized/ colaminated steel.
<b>Inner corners:</b>	Rounded for easy cleaning and ensuring maximum hygiene
<b>Handle:</b>	Stainless steel AISI 304, 2 mm thick
<b>Racks and slides:</b>	Stainless steel AISI 304
<b>Feets:</b>	Stainless steel AISI 304, adjustable h 100-150 mm
<b>Cosmo:</b>	Ready for connection to Cosmo Hub

## Accessories and variants

- Special rack kit for drawers and shelves
- Power supply frequency 60Hz
- Other special voltage
- Half doors
- Frame for fixed masonry plinth
- RAL customisable colouring
- Master Marine solutions
- Predisposition for connection to CO2 remote control unit
- Plug-in water unit
- Kit für Öffnung der Tür mit Pedal
- 4 Swivel and brake castors h 128 mm
- Stainless steel shelf GN1/1
- Plastic coated shelf GN1/1
- Pair of type C slides 505 mm
- Stainless steel drawer, h 150 mm 350
- Bottles shelf, stainless steel coating for shelf 350
- Serial interface, RS485 cable
- Cosmo connection kit

## COSMO - wi-fi control

Cosmo is the wi-fi technology that allow to connect and monitor all Coldline appliances. Connect Master cabinets to a Cosmo hub (MODI, VISION or LEVTRONIC) and from the app you can check the operating conditions of each machine and receive alerts in case of abnormal functioning.

\*The installation requires a kit for the replacement of the racks

## Technical draw

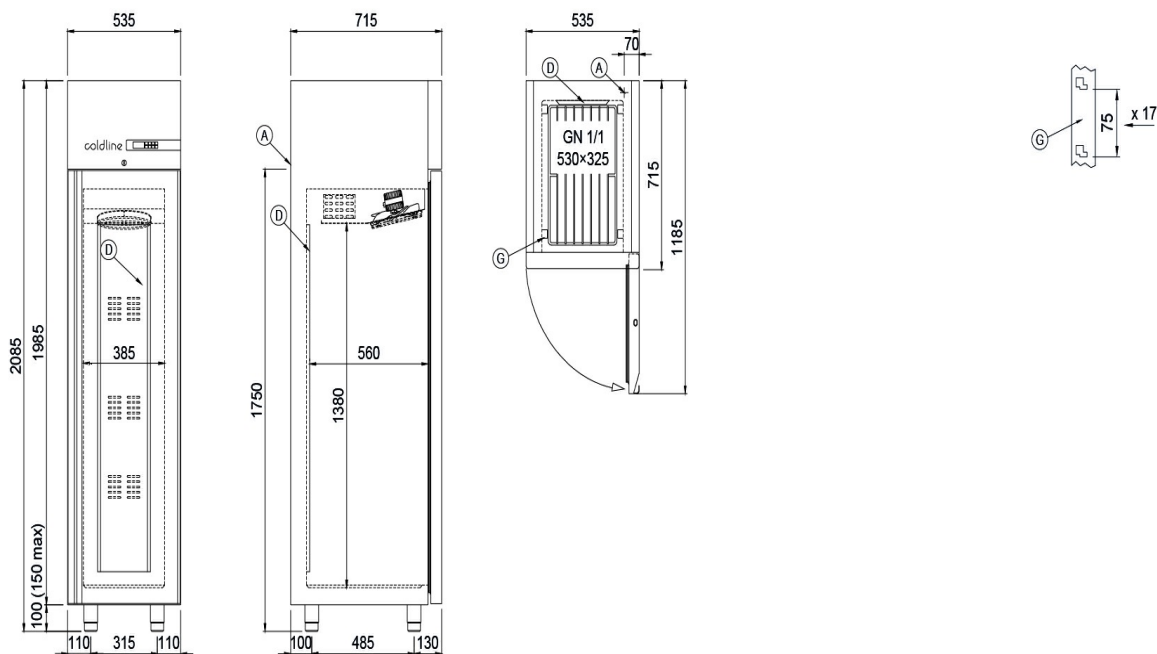

A: Power supply cable outlet

D: Airflow conveyer

G: Racks pitch

In order to constantly offer the best possible products we reserve the right to make changes on technical specifications without incurring any obligation for equipment previously or subsequently sold.